

## 4. Kitchen

### (1) Sink and Cooking Stove Stand

Using abrasive cleansers on kitchen sink and cooking stove stand can cause scratching. For everyday cleaning, please wash with a neutral detergent and rinse well. Failure to clean away dirt can lead to corrosion of the counters, despite their being made of stainless steel.

Grease stains, in particular, stick to not only the cooking stove but also to the kitchen walls, hanging cupboard, and drainer rack. Please wipe the stains every day to make sure it stays keep clean.



### (2) Kitchen Sink Drain Fittings

The catch tray is to prevent kitchen waste from entering the drain. The "bowl" is one part of the fitting and is usually full of water (shaded part of diagram at right). Its purpose is to prevent odors coming up from the drains. Please note the following points to ensure that your kitchen remains pleasant to use.

- ◎ Make sure that rice, tea leaves, and other waste does not get washed into the drain.
- ◎ You can easily remove the catch tray (rubber cover), strainer (catch), and bowl to clean out the waste. However, do not remove the catch tray or bowl other than for cleaning.

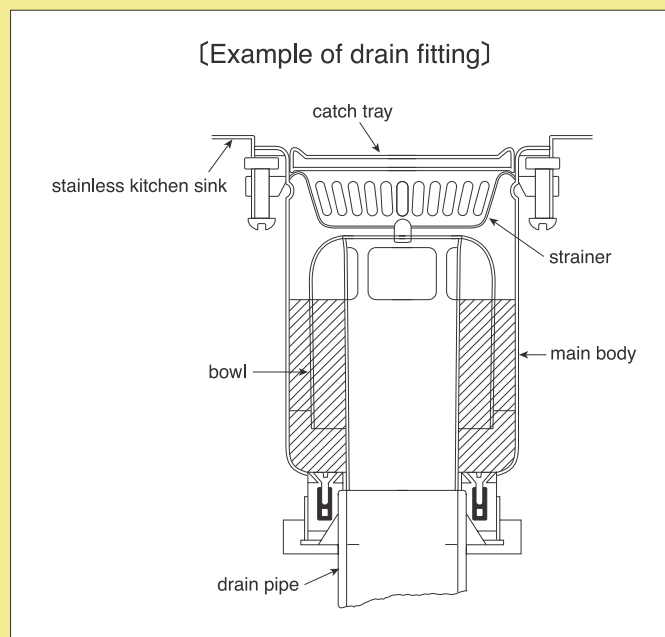

### ◆ If Your Sink should become blocked ◆

Kitchen sink drains are prone to scale buildup. Please take extra care not to wash waste oil from frying down the drain.

If water does not drain easily from your sink, ask for advice at the Administration Service Office or Residence Center or other management facilities.

Any fees that must be paid in relation to cleaning or repairing the drains will be your responsibility.

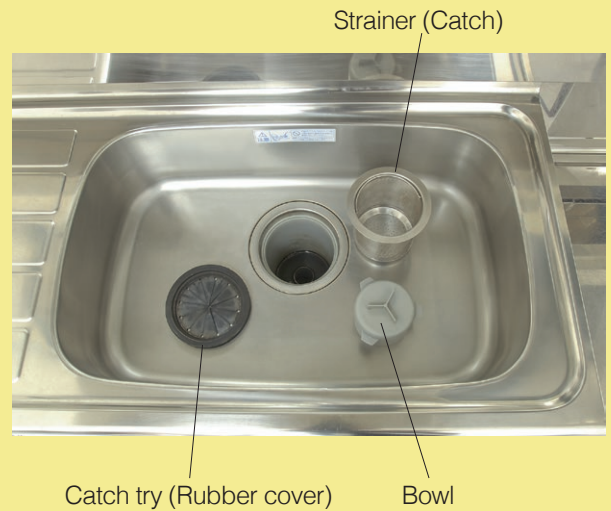

## (3) Ventilation Fans

### ◆ Wall-mounted ventilation fans ◆

When you cook, always use the kitchen fans to quickly remove all exhaust and odors emitted from the cooking range.

In addition, clean the propellers of wall-mounted fans and the grease filters on range hood fans once a month using warm water and neutral detergent.

Stains are easily removed if you clean the fans regularly. **For more information, see the manual for your kitchen fan.**

